

NAVIGATION SYSTEM FOR BLIND PEOPLE USING GPS & GSM TECHNIQUES

Kalpana Singh¹, Mansi Vashisht², Jyoti¹, Istuti Nirmal Saxena¹,
Harshita Tyagi¹, Divya Saxena¹

¹U.G. Scholars, ²Assistant Professor, Deptt. of E&C Engg., MIT Moradabad,
Ram Ganga Vihar, Phase-II, Moradabad (244001), India.

ABSTRACT

In this paper the current state of research and development on global positioning systems (GPS)-based navigation systems for the visually impaired. In this project a walking stick has been designed to help the blind person to detect obstacles and navigate towards the destination. The proposed walking stick consists of a microcontroller, infrared sensors, a GPS receiver, label surface detection, a buzzer and a vibrating motor. The detection of obstacles is done by an array of infrared sensors. The GPS receiver has been used for navigation purpose as well GSM will act as a mobile phone which informed about the danger of blind person. In order to make this stick useful for a blind as well as a deaf person a vibrating motor is used to generate vibrations near the handle of the stick to detect the presence of obstacles. This whole setup will be mounted on the cane. Every effort is being made to make this cane cheaper as well as user friendly.

As the technology is advancing day to day, the human machine interaction has become a must in our daily life. The primary objective of this work is to permit blind persons to explore autonomously in the outside environment. The proposed work is to use a stick including a GPS Navigator. Now a days a stick are used with some features but in our project we are using GPS module with some other advance features.

This work goes for giving the route to blind person by designing a cost effective and more flexible navigation system. The proposed system consists of hardware and software. Here the components we are using are Microcontroller, GPS module, etc. This project will help the blind people in improving their communication ability and not to depend on none during walking in even unknown areas.

KEYWORDS: *Microcontroller, IR Sensor, Label Sensor, GPS Module, GSM Module, MAX232, Power Supply.*

I. INTRODUCTION

Modern world has met different types of technique. Visually challenged persons face constraints in independent mobility and navigation. Mobility means the possibility of liberally moving, without support of any supplementary person, at home and unfamiliar scenarios. People with visual impairment tackle enormous limitations in terms of mobility. A system which guide or assist people with vision loss, ranging from partially sight to totally blind, by means of sound commands is referred as Navigation assistance for visually impaired (NAVI). Many researches are being conducted to build navigation system for blind people. Most of these technologies have limitations as its challenge involves accuracy, usability, interoperability, coverage which is not easy to overcome with current technology for both indoor and outdoor navigation.

In this paper we are focusing on various previous model and proposed work regarding the following paper. All previous paper are using different technologies such as zigbee module, Peripheral interfacing microcontroller, Ultrasonic Sensor, Touch screen sensor.

In our proposed work we have used 12v battery which is converted into 5v by using regulator whose current is divided into the rest of the component. Here we are using IR Sensor which on facing obstacle sends information to controller by the help of which buzzer and vibrator helps in indicating

blind person. The use of GPS helps to find the location where as the use of GSM helps in finding the location of the blind person by the help of latitude and longitude.

II. LITERATURE SURVEY

[1] DR BOYINA.S.RAO: This paper presents the architecture as well as the implementation of the system that helps the visually impaired person to navigate autonomously in the indoor environment. This method utilizes the Global Positioning System (GPS) and it also incorporates object avoidance technologies. The system applies a ZigBee protocol to provide the continuous tracking of the visually impaired person. It also consists of additional components like ATMEGA microcontroller, ultrasonic sensor and microphone to provide more refined location and orientation information. The visually impaired person issues the command and receives the direction response using audio signals. The latitude and longitude values are received continuously from the GPS receiver and then transferred to the PC using the ZigBee transceivers, using these values the localization of the visually impaired person is attained using Google map. The goal of this work is to allow the visually impaired persons navigate independently in the indoor environment. Conventional navigational systems in the indoor environment are expensive and its manufacturing is time consuming. The visually impaired are at considerable disadvantage as they often lack the information needed while passing obstacles and hazards. They have relatively little information about land marks, heading and self-velocity information that is essential to navigate them successfully through unfamiliar environments. In this modern world providing security to each and every human being in life gains a major consideration. Everyone has realized the need to secure themselves against hazards and unauthorized dealings. This work aims at providing the navigation for the visually impaired persons, by designing a cost – effective and more flexible navigation system. It is our belief that the recent advances in technologies could help and facilitate in day – day operations of visually impaired persons.

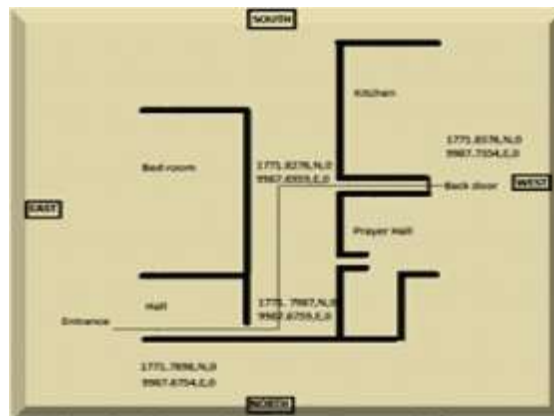

Fig 2.1: General block diagram (Tx and Rx section)

[2] CHAITALI K. LAKDE: Traditionally white cane is the most popular, simplest tool for detecting obstacles due to its low cost, portability. It enables user to effectively scan the area in front and detect obstacles on the ground like holes, steps, walls, uneven surfaces, downstairs etc. But it can only be used to detect obstacles up to knee-level. Its detection range is limited up to 1-2 feet only. Certain obstacles (e.g. protruding window panes, raised platforms, a moving vehicle, and horizontal bars) cannot be detected till they are dangerously close to the person. Even dog guides are very capable to guide these persons but they are unable to detect potentially hazardous obstacles at head level. Guide dog service stage is on average 6 years and requires regular dog up-keeping expenditure and lifestyle changes. Present Solutions on Above Problems Several solutions have been proposed in the recent years to increase the mobility and safety of visually impaired persons. A system “Roshni” determines the user’s position in the building, navigation via audio messages by pressing keys on the mobile unit. It uses sonar technology to identify the position of user by mounting ultrasonic modules on ceiling at regular intervals. This system is portable, easy to operate and is not affected by environmental changes. But this system is limited only for indoor navigation because it requires detailed interior map of the building. RFID based map-reading system which provides technical solution for the visually

impaired to pass through public locations easily using RFID tag grid, RFID cane Reader, Bluetooth interface and personal digital assistance. But its initial development cost is quite high and chances of interference in heavy traffic.

A voice operated outdoor navigation system developed using GPS, voice and ultrasonic sensor. It can alert user's current position and provide verbal guidelines for travelling to a remote destination but fails to give obstacle detection and warning alert.

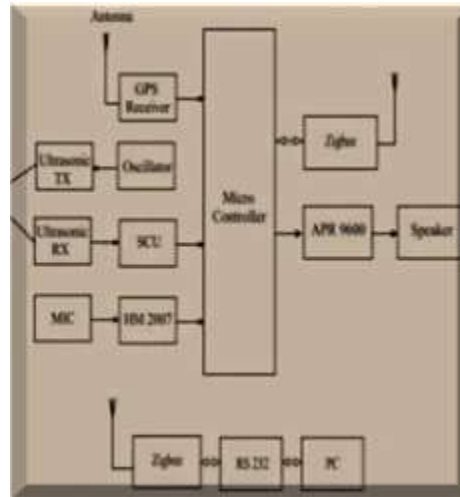

Fig 2.2: GPS Component

[3] PRANJALI R PHIRKE: she has design an device which is named as Location Finding for Blind People Using Voice Navigation Stick The paper main objective is to provide a talkative assistance to blind people. We are going to develop an intelligent system that works efficiently good in both indoor and outdoor. Current navigation device for the visually impaired focus on travelling from one location to another. This focuses on designing a device for visually impaired people that help them to travelling independently also it must be comfortable to use. The proposed device is used for guiding individuals who are blind or partially sighted. The device is used to help blind people to move with the same ease and confidence as a sighted people. The device is linked with a GPS to identify the location of the blind person. Moreover, it provides the voice alert to avoid obstacles based on ultrasonic sensors. An emergency button is also added to the system. A RFID can be installed into public building and it is also integrated into blind persons walking stick .The whole device is designed to be small and is used in conjunction with the white cane.

An attempt has been made to make a compact and portable device which is exclusively designed for visually impaired people. It will allow the visually impaired person to travel through an unfamiliar environment with ease. It can be said that the project provides Silicon Eye for visually impaired people. The design and architecture of a new concept of Smart Electronic Travel Aid Stick for blind people. The advantage of the system lies in the fact that it can prove to be a very low cost solution to millions of blind persons worldwide. The proposed combination of various working units makes a real-time system that monitors position of the user and provides dual feedback making navigation more safe and secure. This system is intended to provide overall measures object detection and real-time assistance via Global Positioning System (GPS). The system consist of ultrasonic sensor, sonar sensors, GPS Module, GSM Module and vibratory circuit (speakers or head phones). When the object is detected near to the blinds stick it alerts them with the help of vibratory circuit (speakers or head phones). The location of the blind is found using Global System for Mobile communications (GSM) and Global Position System.

[4] HARSHA GAWARI: There are many systems which are designed to help navigate the visually impaired. SWAN (System for Wearable Audio Navigation) consists of a laptop, a tracking chip, GPS sensors, 4 cameras and headphones. The sensors and tracking chip send data to the laptop having the SWAN application which then computes the location and the direction where the blind person is looking. A travel route is mapped and 3D audio cues are sent to the head phones to guide the person along a path to the destination. The disadvantage of this system is that it needs many sensors, 4

cameras that makes the system complex and expensive. Another system called SESAMONET (Secure and Safe Mobility Network) uses RFID microchips which are embedded in the ground.

This is used to guide the visually impaired through a predefined area. Each microchip sends position signals through a walking stick to the smart phone. The disadvantage of this system is that it requires many RFID microchips and it is not possible to put so many chips for long distance. Hence the system is expensive. The system explained here provides the details to the users regarding where at present he/she is located and spoken directions to travel to a remote destination. The visually impaired often lack the needed information for bypassing obstacles and hazards and have relatively little information about landmarks, heading, and self-velocity. This puts them into considerable disadvantage compared to sighted individuals navigating through familiar environments who have knowledge of these environments or who are navigating through unfamiliar environments on the basis of external maps and verbal directions to make a navigation system use friendly and accessible to the greatest proportion of vision impaired people, usability is a key focus of the project, and speech technology was identified as a priority feature of the system. Further, by replacing the Braille keyboard with a speech technology, the device will be more portable and less cumbersome to use while walking. Speech technology has been under development for more than three decades.

[5] ABDEL ILAH NOUR ALSHBATAT: The system is Automated Mobility and Orientation System for Blind or Partially Sighted People Currently, blind people use a traditional cane as a tool for directing them when they move from one place to another. Although, the traditional cane is the most widespread means that is used today by the visually impaired people, it could not help them to detect dangers from all levels of obstacles. In this context, we propose a new intelligent system for guiding individuals who are blind or partially sighted. The system is used to enable blind people to move with the same ease and confidence as a sighted people. The system is linked with a GSM-GPS module to pin-point the location of the blind person and to establish a two way communication path in a wireless fashion. Moreover, it provides the direction information as well as information to avoid obstacles based on ultrasonic sensors. A beeper, an accelerometer sensor and vibrator are also added to the system. The whole system is designed to be small, light and is used in conjunction with the white cane. The results have shown that the blinds that used this system could move independently and safely.

III. COMPARISON FROM OTHER RESEARCH

Literature survey shows that different researches are done in the field of blind stick using navigation system but our proposed work is quite different from other researchers. Many researches use Zigbee module and ultrasonic sensor for detection purpose but we are using GPS and GSM technology which is quite familiar and easy to use and have some advantages on other technology such as now a day's all the devices have built GPS module such as smart phones, Laptops ,Cars etc.

The previous researches are focusing on using stick with only voice recognition module and ultrasonic sensor to detect the path where as we are focusing on ease of person by using GPS as well sensor so the device locate the position of the server and a server can easily find his way.

IV. PROBLEM IDENTIFICATION

Under problem identification the problem and difficulty faced in development of technologies like interfacing of different sensors, programming of LM339 IC with microcontroller so both condition cannot collapse each other. The problem that were faced are as follows

- Components availability
- Designing of circuit
- Choosing of right component at right place
- Programming of each sensor
- Placing a component in a stick in such a way so that a person feels no difficulty while using the stick.

V. DESIGN AND IMPLEMENTATION OF PROPOSED WORK

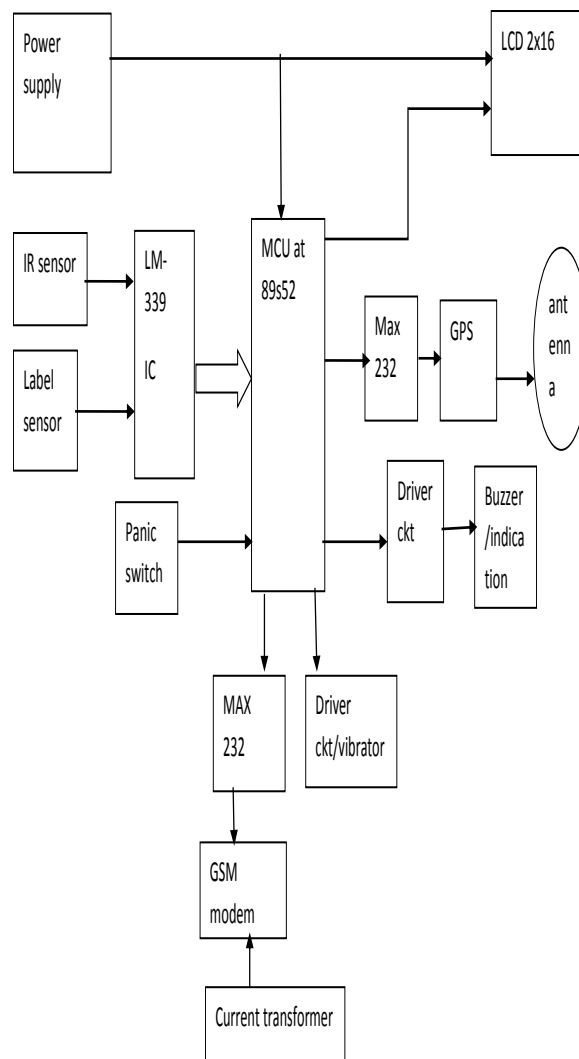

FIG 5.1: Block diagram of direction of blind person using GPS Navigator.

The project contains various devices for the operation of the stick these devices include Microcontroller, Infrared sensor, GPS and GSM module, Label sensor etc.

❖ IR SENSOR:

The IR Sensor is known as infrared sensor .In our proposed work the IR sensor having an one led and one photodiode, when an any obstacle comes in front of the sensor, it starts indicating about the obstacle. Although vibrator and the buzzer will indicate by their work.

❖ LABEL SENSOR:

In this project the label sensor is used for the safety of blind person, in a way as there is any obstacle like stairs or pothole on roads then this sensor will sense such things and indicate the blind person to beware from accident.

❖ MICROCONTROLLER AT89S52:

AT89s52 is a low power, high performance 8bit microcontroller. It operate at low voltage of 5v,it has four ports each port has it's own function through which all the device used in in the project are performed.

❖ GPS MODULE:

The GPS module stands for Global Position System, it act as a receiver to identify the location of blind person in order of longitude and latitude. If there is a slight change in the distance as well as the direction of blind or deaf person there will be a change in latitude and longitude.

❖ **GSM MODULE:**

The GSM stands for Global System for Mobile communication, it acts as mobile phone which send message to any person linked to GSM while the blind person is in danger. When we are inserting a SIM-card to GSM it act as mobile phone while the blind person press the panic switch during danger the SMS goes to the another person and he can easily find out the location of blind person with the help of latitude and longitude.

VI. FINAL REPRESENTATION OF PROJECT



Fig 6.1: Final representation of project

In final representation of the project a stick is used in which the design is being implemented. In the circuit design we are using a 12V power supply for the proper functioning of whole circuit. The LCD is being used to display the latitude and longitude received by the GPS receiver. The project is utilizing various sensors like IR sensor to detect the obstacle coming in front of the person, another device we are using is Label sensor to detect the label of the porthole or other obstacle and indicate to blind person with the help of vibrator and buzzer.

VII. RESULT

In final result the project is working properly with all proper arrangements. In result we are showing all the devices used in the project.

PCB BOARD:



FIG 8.1: PCB Board

As we see in the figure the PCB Board contain various different device like power supply of 12v, a comparator which work as an optical amplifier for IR Sensor and Water label Sensor, a LM399 IC is being used for the proper functioning of all the devices whose work is to give command to all the equipment used in stick , here we are also using Led for showing longitude and latitude received by the GPS receiver. The buzzer as well as a vibrator is also used for indicating a blind person in any unwanted situation.

GPS AND GSM MODULE:



FIG 8.2: GPS and GSM MODULE

Here we are using GPS and GSM Module. The function of GPS in our project is to catch signal from satellite and provide location to the blind person. The function of GSM in our project is that it act as mobile whenever a person is in danger we had provided a panic switch which will be pressed by the person and the another person whose number is linked with the GSM provide a proper location of blind person with proper “ latitude and longitude”.

IR SENSOR:

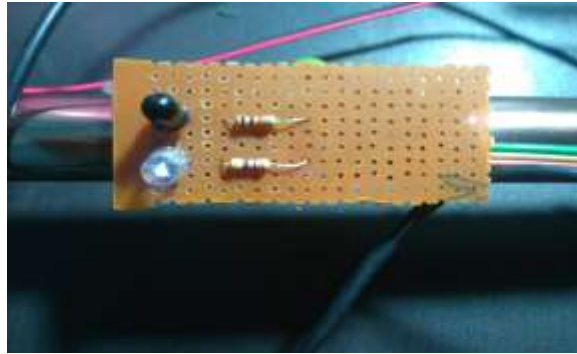

FIG 8.3: IR SENSOR

The fig shows IR Sensor which will help in detecting obstacle comes in front of the blind person. The range of IR sensor is 25m which will easily detect the obstacle comes under this range.

FINAL REPRESENTATION:

The overall circuit is look in this way.



FIG 8.4: Final Representation

VIII. CONCLUSION

The proposed work has the scope of widespread in indoor and outdoor application. It can also be used to analyze the surrounding of person without any human intervention. The stick we used in our project is easy to use by visually impaired people. It has a wide use in future. The project demonstrates a proper working and complete character.

IX. FUTURE WORK

1. The principles of mono pulse radar can be utilized for determining long range target objects.
2. It includes a new concept of optimum and safe path detection based on neural networks for a blind person.
3. During so, we can track the moment of the blind person in a very efficient manner.

ACKNOWLEDGEMENT

The author expresses his sincere gratitude to Professor Mansi Vashisht of the department of electronics and communication engineering at Moradabad Institute of Technology for his valuable advice and guidance throughout the project. Thanks are due to Professor Amit Saxena for his constructive suggestions for his continuous support to complete the project successfully. At last author would like to thanks their parents for their cooperation.

REFERENCES

- [1] Dr Boyina.S.Rao "Blind Assistant Navigation System" in IEEE Transactions, March 2011. Ulrich and J. Borenstein, "The GuideCane — Applying Mobile Robot Technologies to Assist the Visually Impaired" in IEEE Transactions on Systems, Man, and Cybernetics, —Part A: Systems and Humans, Vol. 31, No. 2, March 2001, pp. 131-136.
- [2] Chaitali K. Lakde, B. Blasch, W. R. Wiener, and R. L. Welsh, Foundations of Orientation and Mobility, 2nd ed. New York: AFB Press, 1997.
- [3] Pranjali R Phirke, Alshbatat, Abdel IlahNour. "Automated Mobility and Orientation System for Blind or Partially." International Journal on Smart Sensing and Intelligent Systems, 568-582, 2013.
- [4] HarshaGawariSomnathKoley, Ravi Mishra," Voice Operated Outdoor Navigation System For Visually Impaired Persons", International Journal of Engineering Trends and Technology- Volume3Issue2- 2012.
- [5] Abdel IlahNourAlshbatat Chaudhry M., Kamran M., Afzal S., "Speaking monuments — design and implementation of an RFID based blind friendly environment." Electrical Engineering, 2008. ICEE 2008. Second International Conference on 25-26 March 2008 Page(s):1 –
- [6]. Punwilai, J. Noji, T. Kitamura, "The design of a voice navigation system for the blind in Negative Feelings Environment", Communications and Information Technology, ISCIT 2009.
- [7]. Kaminski, L. Kowalik, R. Lubniewski, Z. Stepnowski, "VOICE MAPS — portable, dedicated GIS for supporting the street navigation and self- dependent movement of the blind", Information Technology (ICIT), 2010.
- [8]. Helal, A. Moore, S.E. Ramachandran, "Drishti: an integrated navigation system for visually impaired and disabled", Wearable Computers, 2001.
- [9]. Marsh, A. May, M. Saarelainen, "Pharos: coupling GSM and GPS TALK technologies to provide orientation, navigation and location based services for the blind", Information Technology Applications in Biomedicine, 2000.
- [10]. P. Baranski, P. Strumillo, M. Bujacz, A. Materka," A Remote Guidance System Aiding the Blind in Urban Travel", 1999. [6]. Somnathkoley, Ravi Mishra," Voice Operated Outdoor Navigation system for visually Impaired Persons", 2012. [1] B. Ando, S. Baglio, S. La Malfa, and V. Marletta. March 2011. A sensing architecture for mutual user- environment awareness case of study: A mobility aid for the visually impaired. IEEE Sensors J. 11(3): 634- 640.
- [11] B. Stollberg and T. De Groeve. 2012. The use of social media within the global disaster alert and coordination system (GDACS). In: Proc. 21st Int. Conf. Companion World Wide Web. pp. 703-706.
- [12] Betsworth, N. Rajput, S. Srivastava, and M. Jones. 2013. Audvert: Using spatial audio to gain a sense of place. in Human-Computer Interaction-INTERACT), P. Kotz'e, G. Marsden, G. Lindgaard, J. Wesson, and M. Winckler, Eds. Berlin, Germany: Springer. pp. 455-462.
- [13] S.Ranjith, T.Ravi, P.Umarani, R.Arunya. 2014. Design of CNTFET based sequential circuits using fault tolerant reversible logic. International Journal of Applied Engineering Research. 9(24): 25789-25804.
- [14] D. McGookin and S. Brewster. 2011. PULSE: An auditory display to provide a social vibe. In: Proc. Interacting Sound Workshop: Exploring Context- Aware, Local Soc. Audio Appl. pp. 12-15.
- [15] PelinAngin and Bharath K. Bhargava. 2011. Real- time Mobile-Cloud Computing for Context-Aware Blind Navigation. International Journal of Next- Generation Computing. 2(2).
- [16] S. L. Joseph, X. Zhang, I. Dryanovski, J. Xiao, C. Yi, and Y. Tian. 2013. Semantic indoor navigation with a blind-user oriented augmented reality. In: Proc. IEEE Int. Conf. Syst., Man, Cybern. pp. 3585-3591.

- [17] Ravi.T. 2015. Design and performance analysis of ultra low power RISC processor using hybrid drowsy logic in CMOS technologies” International Journal of Applied Engineering Research (IJAER). 10(2): 4287-4296.
- [18] Samleo L. Joseph, Jizhong Xiao. June 2015. Being Aware of the World: Toward Using Social Media to Support the Blind with Navigation. IEEE transactions on human-machine systems. 45(3).
- [19] Sha Tao, VasileiosManolopoulos, Saul Rodriguez, Ana Rusu. 2012. Real-Time Urban Traffic State Estimation with A-GPS Mobile Phones as Probes. Journal of Transportation Technologies. 2, 22-31.
- [20] Samuel Lazar.M, Ravi.T. 2015. Li-Fi design for high speed data transmission. ARPN Journal of Engineering and Applied Sciences. 10(14): 5999- 6003.
- [21] Y. T. Chucai Yi. 2013. Text extraction from scene images by character appearance and structure modeling. Comput. Vis. Image Understanding. 117(2): 182-194.
- [22] D. Dakopoulos and N.Bourbakis. Jan 2010. Wearable obstacle avoidance electronic travel aids for blind: A survey. IEEE Trans.Syst., Man, Cybern. C, Appl. Rev. 40(1): 25-35.
- [23] V.S.M. MadulikaS, M.S. Madhan Mohan, CH. Sridevi, T.V. Janardhanarao. Dec 2013. Arm7 Based Electronic Travel Aid System for Blind People Navigation and Monitoring, International Journal of Research in Computer and Communication Technology. 2(12).
- [24] Olivier Venard, Geneviève Baudoin, Gérard Uzan, —Field Experimentation of the RAMPE Interactive Auditive Information System for the Mobility of Blind People in Public Transport : Final Evaluation| Intelligent Transport Systems Telecommunications,(ITST),2009 9th International Conference, Oct. 2009.
- [25] Syed Rizal Alfam Wan Alwi, Mohamad Noh Ahmad, —Survey on Outdoor Navigation System Needs for Blind People,| IEEE Student Conference on Research and Development (SCOREd), 2013, pp.144-148.
- [26] DavorVirkes, KarmenNenadic, Diana ZerecVirkes, —Positioning systems for mobility of the blind, overview and analysis,| 46th International Svmposium Electronics in Marine, ELMAR- 2004, 16-18 June 2004.
- [27] Zadar, Croatia Passenger BUS Alert System for Easy Navigation of Blind, 2013 International Conference on Circuits, Power and Computing Technologies [ICCPCT-2013] [5] MounirBousbia-Salah, AbdelghaniRedjati, Mohamed Fezari, MaamarBettayeb, —An Ultrasonic Navigation System For Blind People, IEEE International Conference on Signal Processing and Communications (ICSPC 2007), pp.1003-1006.
- [28] Jin Liu, Jingbo Liu, LuqiangXu, Weidong Jin, —Silicon Eyes: GPS-GSM based Navigation Assistant for Visually Impaired using Capacitive Touch Braille Keypad and Smart SMS Facility,| IEEE paper 2013.
- [29] MohsinMurad, Abdullah Rehman, Arif Ali Shah, SalimUllah, Muhammad Fahad, Khawaja M. Yahya, —RFAIDE – An RFID Based Navigation and Object Recognition Assistant for Visually Impaired People, IEEE paper, 2011.
- [30] Adrien Brilhault, Slim Kammoun, Olivier Gutierrez, Philippe Truillet, Christophe Jouffrais, —Fusion of Artificial Vision and GPS to Improve Blind Pedestrian Positioning,| IEEE paper, 2011. [30] Bin Ding, Haitao Yuan, Li Jiang, XiaoningZang, —The Research on Blind Navigation System Based on RFID.

AUTHOR

Kalpna Singh is a final year undergraduate scholar, Department of Electronics and Communication Engineering from Moradabad Institute of Technology, Moradabad (U.P.). Main area of interest is Embedded System.



Mansi Vashisht (B.Tech, M.Tech pursuing) Assistant Professor ECE Department.



Istuti Nirmal Saxena is a final year undergraduate scholar, Department of Electronics and Communication Engineering from Moradabad Institute of Technology, Moradabad (U.P.). Main area of interest is Embedded System.



Jyoti is a final year undergraduate scholar, Department of Electronics and Communication Engineering from Moradabad Institute of Technology, Moradabad (U.P.). Main area of interest is Embedded System.



Harshita Tyagi is a final year undergraduate scholar, Department Of Electronics and Communication Engineering from Moradabad Institute of Technology, Moradabad (U.P.). Main area of interest is Embedded System.



Divya Saxena is a final year undergraduate scholar, Department Of Electronics and Communication Engineering from Moradabad Institute of Technology, Moradabad (U.P.). Main area of interest is Embedded System.

