

GSM BASED LED SCROLLING DISPLAY BOARD

Hardik Gupta, Puja Shukla, Ankita Nagwekar

Electronics and Telecommunication Engineering, Rajiv Gandhi Institute of Technology
Versoa, Andheri, Mumbai 400053, India
hardikent@yahoo.com, pujas234@gmail.com, ankita26478@yahoo.com

Abstract

Scrolling display board is a common sight today. Advertisement is going digital. The use of led scrolling display board at big shops, shopping centers, railway station, bus stands and educational institutes is becoming an effective mode of communication in providing information to the people. But these off-the-shelf units are somewhat inflexible in terms of updating the message instantly. If the user wants to change the message it needs to be done using a computer and hence the person needs to be present at the location of the display board. It means the message cannot be changed from wherever or whenever. Also the display board cannot be placed anywhere because of complex and delicate wiring. 'GSM based LED Scrolling Display Board' is a model for displaying notices/messages at places that require real-time noticing, by sending messages in the form of SMS through mobile. It is a system wherein the display board need not be reprogrammed to display a new message because it is wireless. The project aims to develop a moving sign board which empowers the user to change the scrolling message using SMS service instantaneously unlike a desk bound device such as PC or laptop. The user can update it even from a remote distant. The SMS is deleted from the SIM each time it is read, thus making room for the next SMS.

I. INTRODUCTION

The project is an implementation to the idea of the wireless communication between a mobile phone and a display board. This model combines the advantages of the microcontroller and wireless technology, to build an effective and accurate communication system. The prototype model developed uses the following major components.

- GSM modem-SIM300
- Microcontroller- Philips P89V51RD2.
- MAX-232 level convertor.
- 5X7 led dot matrix (size-2inch, character size-50mm).

- Shift Register- IC 74LS164.
- LED Driver- IC UDN2981.
- Current limiting Resistors- 220 ohm.

The administrator (user) uses a simple GSM based handset for sending messages to display board. The GSM modem used at the receiver end is used to receive the messages. The sent message is stored in the SIM of the modem. By issuing proper AT commands, it is read from the modem and stored in the microcontroller. In order to reduce the current required for the module and to simplify the hardware and wiring necessary to drive the LEDs this design uses Multiplexing. In this technique, at the max only 30 LED's are glowing at any one time and hence power required for display module is reduced.

The led display board accommodates 5x7 led dot matrix displays with a distance between the rows of pins of 50mm (50mm character height). Six such display matrixes are used to form a 30x7 display area (30 columns, 7 rows). The preprogrammed controller is supplied with the standard character set containing alphabets, but there is also the possibility to program punctuation marks, symbols, numbers and special characters and implement simple graphics. For each character a display pattern in the form of HEX values is stored inside the microcontroller which is termed as look up table. The microcontroller looks for the pattern and sends out the data bits serially and clock signal. This data is shifted by the shift registers. The data is sent on columns and rows are scanned fast which allows the pattern to be displayed because of persistence of vision. The row driver IC is used to source current for LED rows (anodes).

II. BLOCK DIAGRAM

The block diagram of the system is shown in figure 1 and figure 2.

III. CIRCUIT DIAGRAM

There are two major interfacing circuits:

1. The Microcontroller is interfaced with modem via MAX-232 level convertor.
2. The Microcontroller is interfaced with the LED display board.

The circuit diagram is shown in Figure 3 and Figure 4.

IV. HARDWARE PROFILE

A. GSM Modem- SIM300

This is the first block in the receiving section. It consists of a slot for holding SIM (Subscriber Identity Module) card. The message sent by the user is stored in this SIM card.

Major features of this modem are:

- Designed for global market, SIM300 is a Tri-band GSM/GPRS engine that works on frequencies EGSM 900 MHz, DCS 1800 MHz and PCS1900 MHz SIM300 provides GPRS multi-slot class 10 capabilities and support.
- Can be used to send SMS, make and receive calls, and do other GSM operations by controlling it through simple AT commands from microcontrollers and computers.
- The SIM300 allows an adjustable serial baud rate from 1200 to 115200 bps (9600 default).
- Power supply Single supply voltage 3.4V - 4.5V.

B. MAX-232 level convertor

The MAX-232 is a dual driver or receiver that includes capacitive voltage generator to supply EIA-232 voltage levels from a single 5-V supply and converts EIA-232 voltage levels to 5-V TTL/CMOS levels. The level convertor acts as an interface between the modem and the microcontroller.

C. Microcontroller- P89V51RD2

P89V51RD2 is a powerful 40 pin microcontroller which provides a range of features such as:

- 80C51 Central Processing Unit
- 64 kB of on-chip Flash program memory with ISP (In-System Programming)
- 5 V Operating voltage from 0 to 40 MHz
- 64 kB Flash memory
- 1024 bytes of data RAM
- Four 8-bit I/O ports with three high-current Port 1 pins (16 mA each)
- Three 16-bit timers/counters
- Eight interrupt sources with four priority levels.

The microcontroller transmits AT commands to receive the message which is sent by the user. It receives the message and only keeps the message part of the response sent by modem. It provides with the data signal and clock signal for scrolling the message.

D. 5X7 LED Dot Matrix

In a dot matrix display, multiple LEDs are wired together in rows and columns. This is done to minimize the number of pins required to drive them. For example, a 5X7 matrix of LEDs would need 35 I/O pins, one for each LED. By wiring all the anodes together in rows (R1 through R7), and cathodes in columns (C1 through C5), the required number of I/O pins is reduced to 12. Each LED is addressed by its row and column number. In the figure 5, if R4 is pulled high and C3 is pulled low, the LED in fourth row and third

column will be turned on. Characters can be displayed by fast scanning of either rows or columns. This model uses Column anode-Row cathode configuration with data signal on columns and rows are scanned.

E. UDN 2981

The UDN2981 IC is 8-channel source driver IC, used for high-side switching applications that benefit from separate logic and load grounds. These 8-channel source drivers are useful for interfacing between low-level logic and high-current loads. The seven display matrix rows are selected by the outputs of the source driver UDN2981 IC. It is TTL, DTL, PMOS, or CMOS Compatible Inputs. It has 500 mA Output Source Current Capability which is the major requirement for the display board

F. Shift Register IC- 74LS164

74LS164 is a high speed, 8-Bit Serial-In Parallel-Out Shift Register. Serial data is entered through a 2-Input AND gate, synchronous with the LOW to HIGH transition of the clock. The device features an asynchronous Master Reset which clears the register setting all outputs LOW independent of the clock. The use of shift registers minimizes the number of I/O pins required to drive the columns of the LED matrix.

G. Crystal- 22.1184 MHz

The microcontroller clock is supplied by a standard 22.1184 MHz crystal. Such a specific crystal is used in order to have a baud rate of 9600 for serial communication with modem. Also a higher value of crystal is of prime importance in this project which has the effect of reducing the flicker seen in the LEDs.

V. WORKING

A. Reading message from modem.

The GSM modem communicates with the microcontroller through asynchronous serial communication. The baud rate used here is 9600. In the initialization routine at the start of execution of program the values of SCON, TMOD and TH1 are set. The microcontroller transmits a set of AT commands to read the message sent by the user. Following is the list of AT commands used to read the message:

- AT// to initialize the modem
- ATE0.....//to turn echo off
- AT+CMGF=1...//to set the message format to TEXT
- AT+CNMI=2,1,0,0,0.....//notification of new message
- AT+CMGR=1.....//to read the stored message
- AT+CMGD=1.....//to delete the message

For the first three commands, the modem responds to the microcontroller with the message 'OK'. This message is ignored by the microcontroller. After the execution of the final AT command, the GSM modem responds with the following long message.

+CMGR:"REC UNREAD", "sender's number", "Date and time"

Message part here

OK

The microcontroller only keeps the message part and discards the remaining message. This message is stored in the buffer array which is later used to display the message on the dot matrix led module.

B. Display Process

Looking at the circuit diagram shown in Figure 3, it can be seen that the column information for the display LEDs is supplied by the outputs of the six shift register ICs type 74LS164. The seven display matrix rows are selected by the outputs of the microcontroller (P1.0 to P1.7) which control the row driver IC UDN2981. Two port lines from the microcontroller control the shift registers. Port 1.5 is the data signal while P1.6 produces the clock signal. The outputs of UDN2981 are connected to a complete row of LEDs while the outputs of shift registers are connected via current limiting resistors to the cathodes of each column of LEDs. The shift register are capable of sinking current up to 8mA.

The display process begins by writing '0' on all rows. This has the effect of blanking out all the LEDs at the start. The microcontroller will take the ASCII code of the character to be displayed from its internal memory and uses this value to access its corresponding display pattern in a character generator (look up table). The controller will then take the first line of the display pattern and send it out serially to the display shift registers. Any bit in the pattern that is '1' will turn the LED off, any bit that is a '0' will turn the LED on. The controller also generates the clock to transfer this serial data into the shift registers.

This process is repeated for the first line of the other five display matrix. After this, the first pin of the UDN2981 driving the first row (R1) is enabled. All of the shift register outputs that are low will cause these LEDs in the first line to light for a short period. The same process is now repeated for the second row up to the seventh row. In row scanning, each row is selected for a very short time (about 1ms) and the columns are fed with appropriate logic levels. By quickly scanning across the rows (more than 100 times per second), and turning on the respective LEDs in each column of that row, the persistence of vision comes into play, and the display image is perceived as still. This is shown in figure 6.

Figure 7 shows the active LEDs in each row to display the character 'A' in an 8X8 dot-matrix format. This information for all printable ASCII characters (0-9, A-Z, a-z, etc.) is stored in the 2-dimensional character array.

On evaluating the rows, the HEX values for character 'A' are

(0x8f, 0x77, 0x77, 0x77, 0x07, 0x77, 0x77, 0x77)

For the scrolling effect, seven display buffers of size 32 bits are defined, for storing the bit information of 32x7 LEDs in the matrix. The content of this array is what to be displayed on the matrix. The process of scrolling a message starts from right to left. To move the character from right to left, the column values for all rows are shifted to left direction with an appropriate amount of shift step. Once the character has been shifted sufficiently, the row values of next character in the message are fed. This is done after scrolling five times per character, in order to accommodate many characters simultaneously. In each shift, the display buffer is updated.

Figure 9 explains the status of active LEDs for the display module. Here the character 'A' has been shifted 3 times to the left. The values of the Display Buffer [1] for this state is,

11111 11111 11111 11111 11111 11100

Figure 10 explains the status of LEDs after two characters has been shifted. The value of display buffer [1] is

11111 11111 11111 11111 11000 11000

Each character is shifted six times, after which the 5x7 character is fully loaded in to the display buffer. Then, shifting restarts from 1 again and starts loading the next character from the right, while the display buffer itself shifts left. This continues until all the characters in the message are loaded. Once all characters are loaded, the message keeps scrolling till a new message is received. When a new message arrives, the microcontroller automatically stops the display process, extracts the new message from the SIM card and executes the new display process scrolling the new message.

VI. FLOWCHART

The operational flowchart of the system is shown in figure 11 and figure 12.

VII. CONCLUSION

The project explains how we can develop GSM based led scrolling board, by integrating features of all the hardware components used. Presence of every module has been reasoned out and placed carefully,

thus contributing to the best working of the unit. The scrolling board successfully displays the message word by word. The speed of scrolling is controlled using software. The major constraint of flicker and intensity of LEDs is eliminated by the use of high frequency crystal.

Due to the use of multiplexing technique, power dissipated by the LEDs is low. Greater efficiency is achieved by using the concept of wireless communication. The model can be efficiently used in restaurants to display the menu, at railway station in case of cancellation of trains, in educational institutes for faster communication of notices or messages, banks and bus stands.

The system can also be employed in hotels, rooms in cases of emergency. The major advantage of this model is that the person can change the message at any point with no constraint of distance. There can be latency involved in delivering the message to the GSM modem and hence it is advisable to use a high standard modem with good range capability (use of better antenna).

VIII. FUTURE SCOPE

The model can be utilized to display temperature in case when there is no message to be displayed. With proper use of interrupt routines the incoming message will act as an interrupt, the temperature display is halted and the control flow jumps over to the specific interrupt service routine which displays the information field. Another improvement in this model can be of broadcasting the same message to multiple display boards. This can be achieved with the use of clone SIM cards. Multilingual message display can be another variation in this model. The message can be first received, displayed in standard language. The same message can be converted to another language and the message can be displayed.

IX. ACKNOWLEDGEMENT

We would like to thank all the important people who have helped us in completing this paper. We would like to thank our Principal Dr.U.V.Bhosle and Prof. S.D.Patil, H.O.D of Electronics and Telecommunication Department, Rajiv Gandhi Institute of Technology, Mumbai for providing us an opportunity to work on the project GSM Based LED Scrolling Display Board. We sincerely thank our project guide Prof. Surendra Sutar, Department of Electronics and Telecommunication whose help, stimulating suggestions, knowledge and experience helped us at all the time during the study and analysis of the project.

X. IMAGES

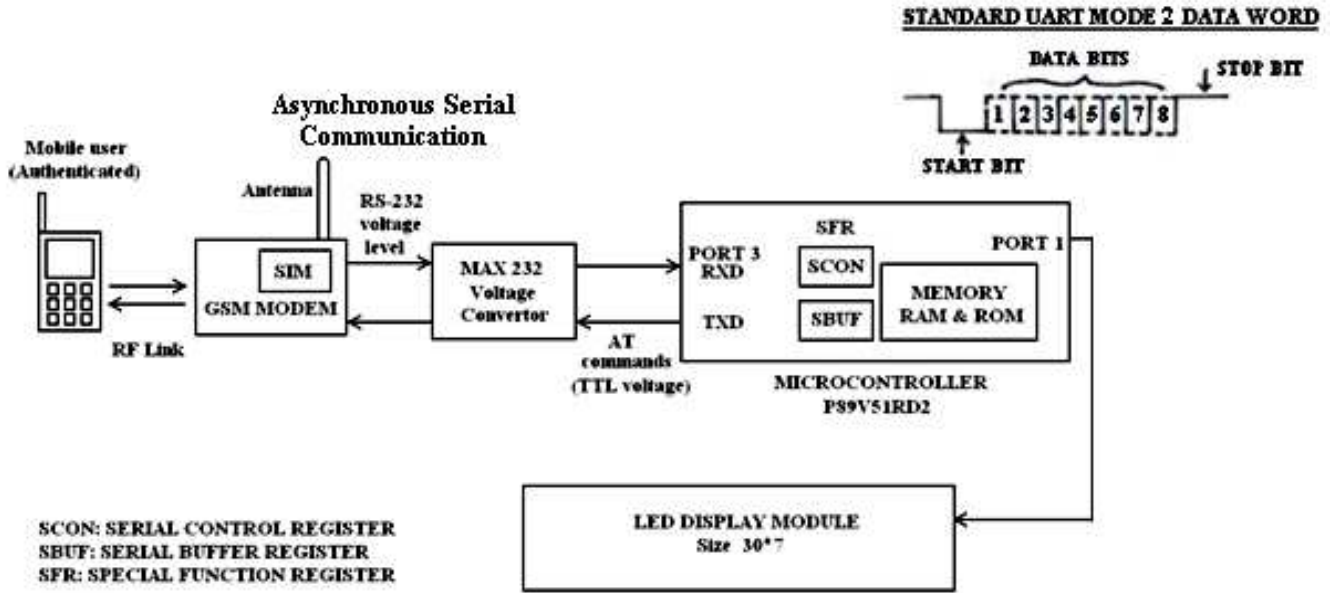

FIGURE 1: BLOCK DIAGRAM OF THE SYSTEM.

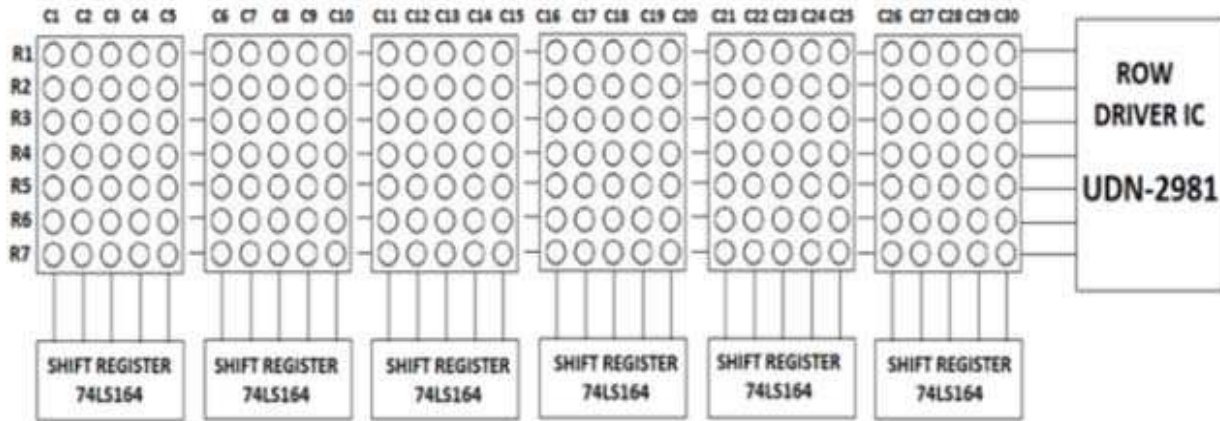

FIGURE 2: LED DOT MATRIX DISPLAY BOARD, 30 COLUMNS AND 7 ROWS.

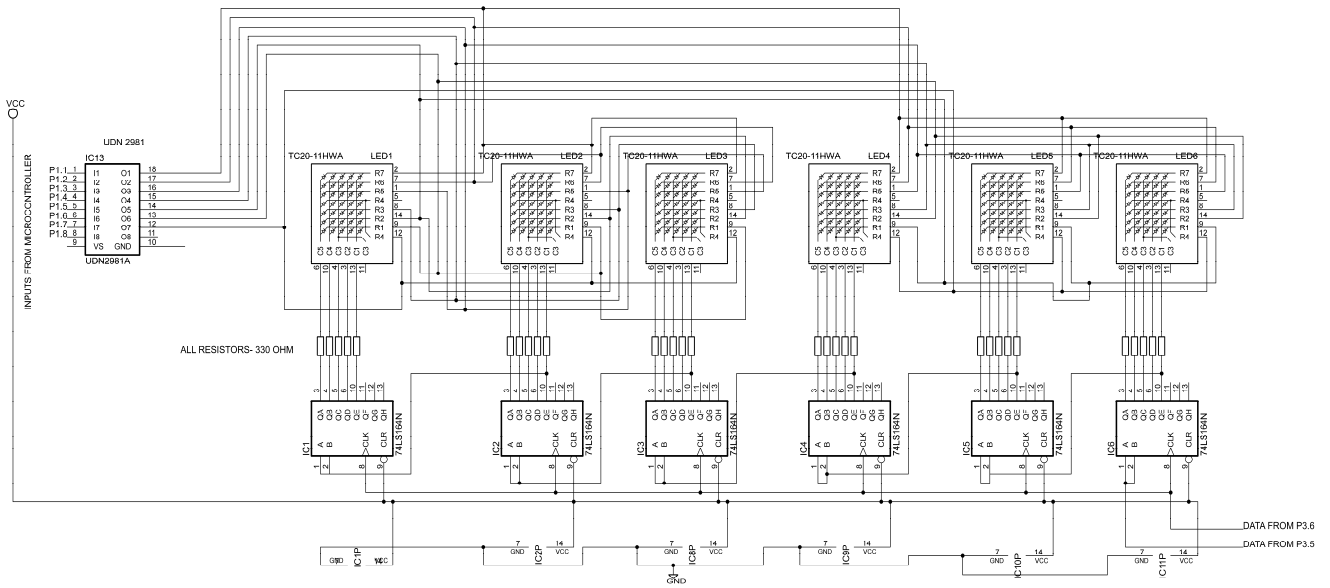

FIGURE 3: INTERFACING OF MICROCONTROLLER WITH LED DISPLAY BOARD.

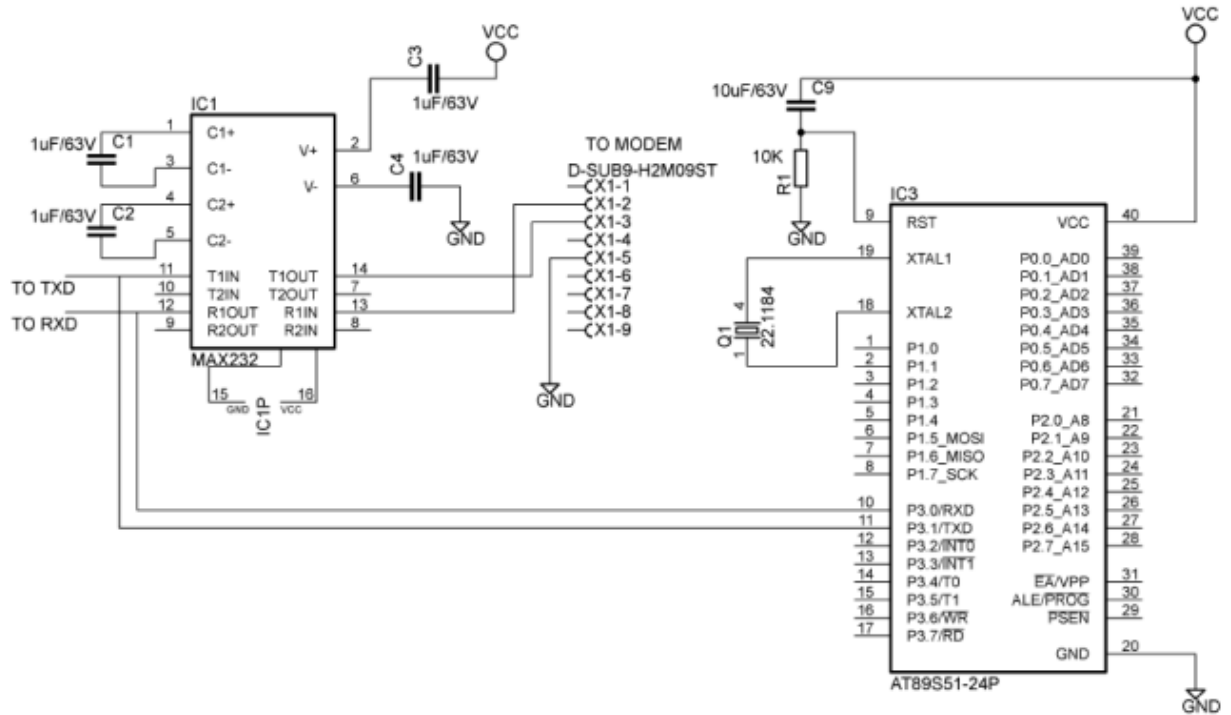

FIGURE 4: INTERFACING OF MICROCONTROLLER WITH GSM MODEM VIA MAX-232

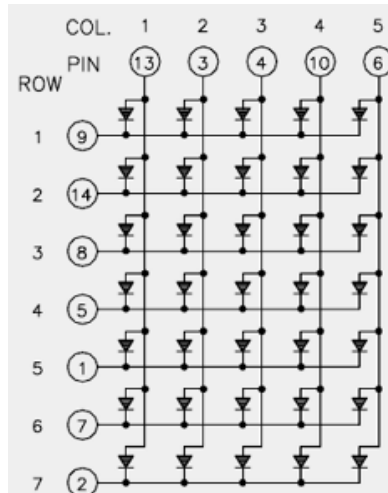

FIGURE 5: COLUMN ANODE AND ROW CATHODE CONFIGURATION OF LED MATRIX.

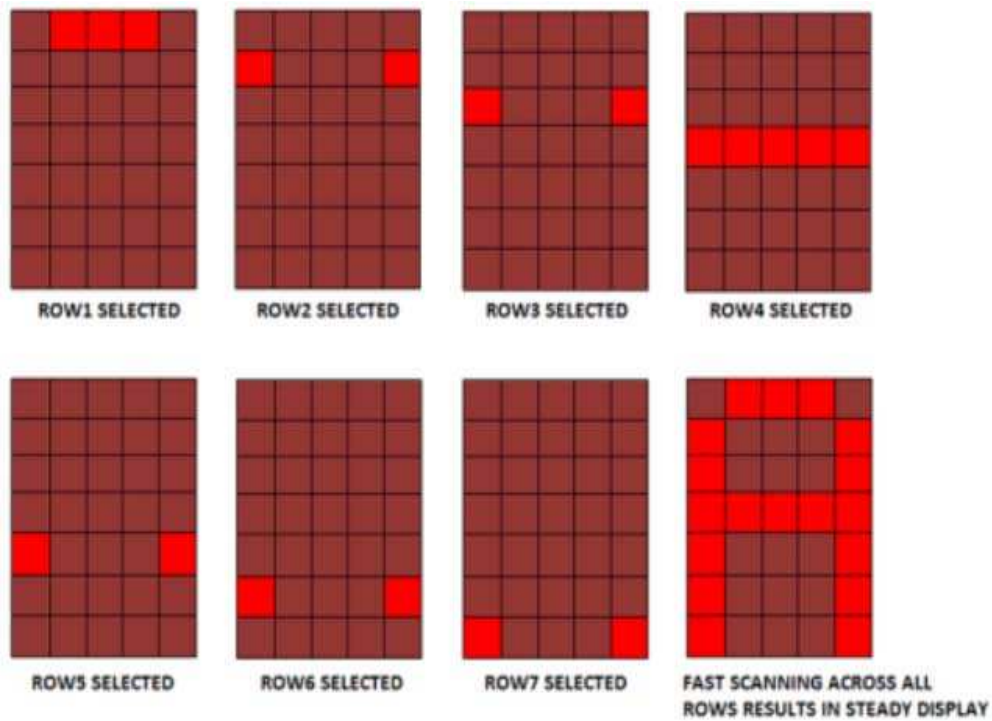

FIGURE 6: ROW SCANNING AND COLUMN DATA.

	c1	c2	c3	c4	c5	c6	c7	c8	
R1		0	0	0					CharacterRow [1]
R2	0				0				CharacterRow [2]
R3	0				0				CharacterRow [3]
R4	0				0				CharacterRow [4]
R5	0	0	0	0	0				CharacterRow [5]
R6	0				0				CharacterRow [6]
R7	0				0				CharacterRow [7]
R8	0				0				CharacterRow [8]

FIGURE 7: DISPLAY PATTERN FOR CHARACTER 'A'

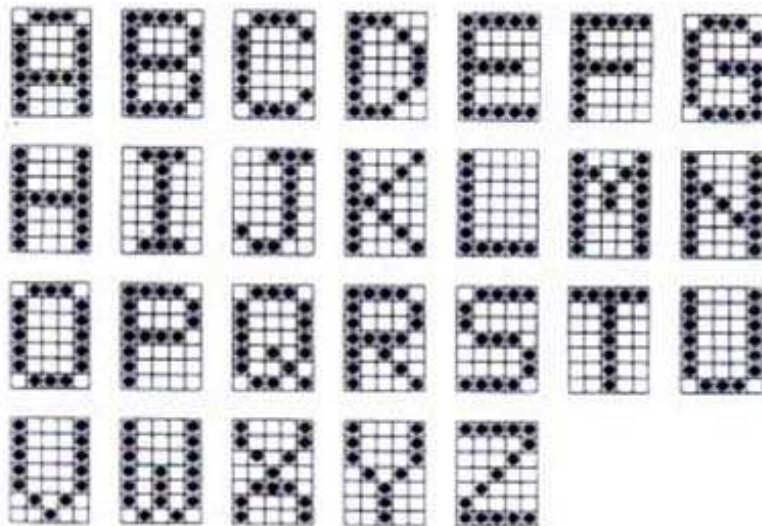

FIGURE 8: DISPLAY PATTERN FOR THE ALPHABETS.

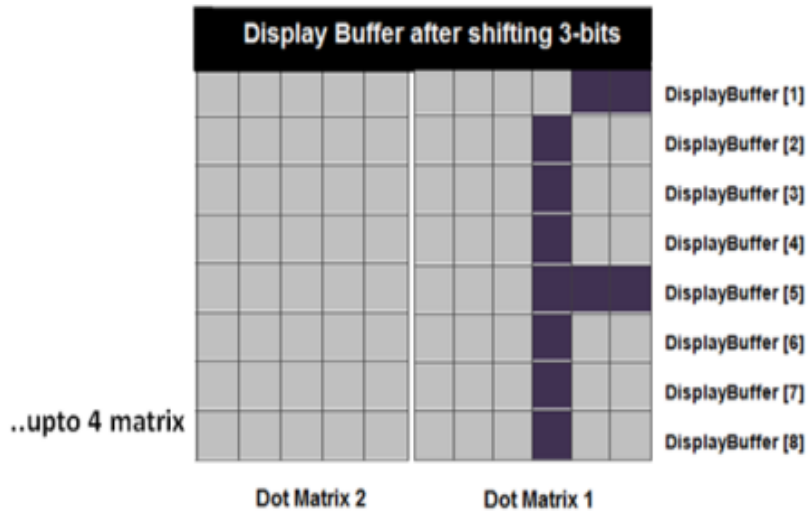

FIGURE 9: DISPLAY AFTER SHIFTING 3 BITS OF CHARACTER 'A'

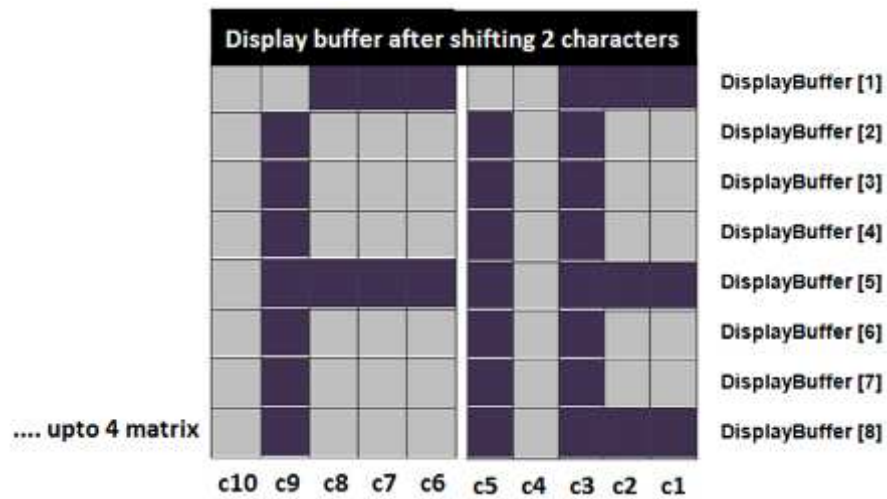

FIGURE 10: DISPLAY BUFFER AFTER SHIFTING 3 BITS

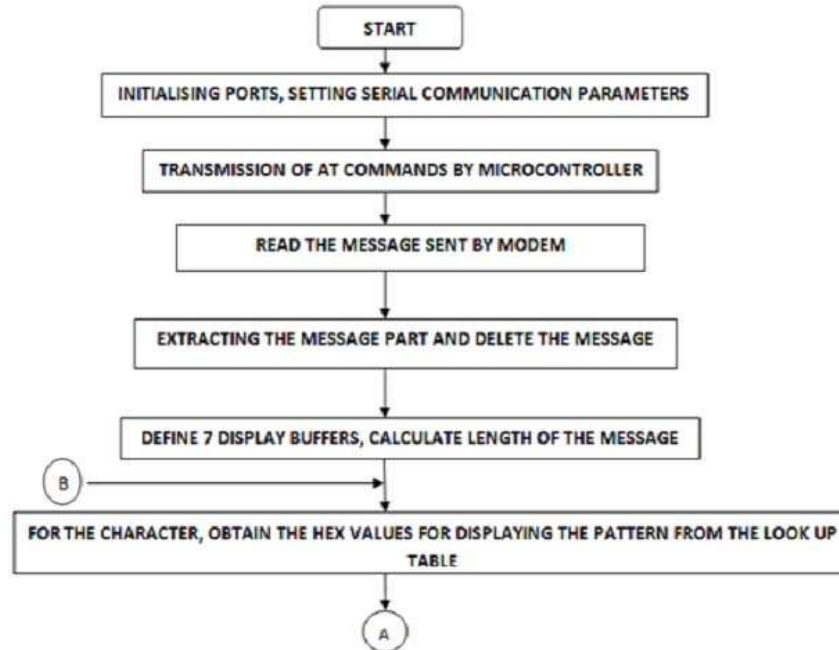

FIGURE 11: FLOWCHART OF THE SYSTEM- 1

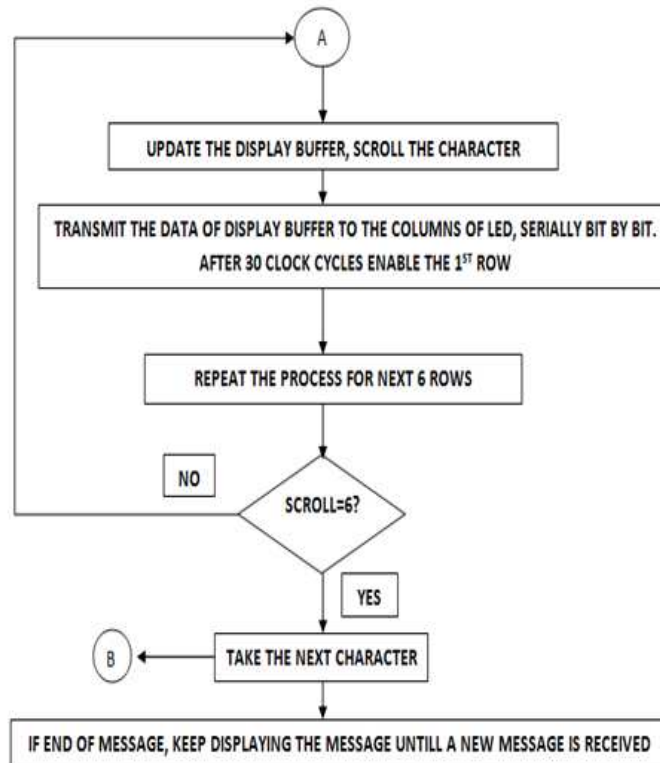

FIGURE 12: FLOWCHART OF THE SYSTEM- 2

XI. REFERENCES

1. Pawan Kumar, Vikas Bhrdwaj, Kiran Pal, Narayan Singh Rathor, Amit Mishra, *GSM based e-Notice Board: Wireless Communication*, IJSCE, ISSN:2231-2307, Volume-2, Issue-3, July 2012.
2. Mrs. S.P.Gaikwad , Manikeshwari Shahdeo , Meghna Priya , Prashant Kr. Raghav, *Wireless GSM Based Electronic Notice Board*.
3. DarshanKumar C.Dadlani, Ninad Trivedi, Amit Kasundra, *Wireless Electronic Notice Board*, National Conference On Recent Trends in Engineering And Technology.
4. *The 8051 Microcontroller and embedded systems* by Kenneth J. Ayala.
5. *The 8051 Microcontroller And Embedded Systems Using Assembly And C* by Janice Gillispie Mazidi, Rolin D. McKinlay, Muhammad Ali Mazidi.
6. probots.co.in/Manuals/SIM300.pdf
7. <http://www.keil.com/dd/docs/datashts/philips/p89v51rd2.pdf>
8. <http://www.datasheetcatalog.org/datasheet/texasinstruments/max232.pdf>
9. <http://www.biltek.tubitak.gov.tr/gelisim/elektronik/dosyalar/27/udn2981.pdf>
10. <http://www.elektor.com/magazines/2001/june/modular-dotmatrixdisplay.54500.lynkx>
11. <http://www.mcu-turkey.com/wp-content/uploads/2010/11/74LS164-SIPO Shift Register.pdf>
12. <http://embedded-lab.com/blog/?p=2661>