



## WAR FIELD SPYING ROBOT WITH NIGHT VISION CAMERA

**Sakshi Balasaheb Chavanke<sup>1</sup>, Tejal Dnyandev Barhate<sup>2</sup>**

*<sup>1,2</sup>Third year Electrical Student, Department of Electrical Engineering,*

*Guru Gobind Singh Polytechnic Nashik Maharashtra(India)*

### ABSTRACT

*Nowadays as there are technological advancements these advancements are used by the military forces for reducing the risk of their casualties and to defeat their enemies. With the development of sophisticated technology, it mostly relies on the high tech weapons or machinery being used. Robotics is one of the hot fields of modern age in which the nations are concentrating upon for military purposes in the state of war and peace. They have been in use for some time for demining and rescue operations but now they are propelled by using them for combat and spy missions. With the aim of the satisfying and meeting the changing needs of human from manufacturing unit to the household unit robotics and automation has been a distinct key player throughout. This project focuses on building a RF based spying robot attached with wireless camera that can reduce the human victim. This robot sends the signal to the base station using wireless camera. One of the major application of this project can be analyzed using android based smart phone which can be used to control the movement of the robot. The robot sends the signal to the RF receiver mounted on the robot via RF transmitter at the base station. With this feature the robot can transmit real time videos with night vision capabilities and cannot be identified by the enemies in war zone.*

***Keywords: Wireless, Robot, RF Technology, Transmission, Reception, War, Spy, Surveillance.***

### I INTRODUCTION

With the aim of developing a high-tech technology that serves high speed technology, advanced capacity to control the robots and to device new methods of control theory. The realize above standards some technical improvement along with the need of high performance robot is required to create a faster, reliable, accurate and more intelligent robot which can be devised by advanced control algorithm, robot control devices and new drivers. Earlier the robots were controlled through wired networks but now to make robot more users friendly, they are framed to make user commanded work. Therefore to attain the requirements we can use android as a multimedia to control the user friendly robot. Robotics is the branch of mechanical engineering, electrical engineering and computer science that deals with the design, construction, operation and application of robotics, as well as computer systems for their



control, sensory feedback and information processing. The aim of developing a high-tech technology serves the purpose of achieving high speed technology, advanced capacity to control the robots and to devise new methods of control theory. The realization of above standards some technical improvement along with the need of high performance robot is required to create a faster, reliable, accurate and more intelligent robot which can be devised by advanced control algorithm, robot control devices and new drivers.

## II. RF SECTION BLOCK DIAGRAM

Let us take a RF transmitter wiggling an electron in one location. This wiggling will electron cause a ripple effect, somewhat same to dropping a pebble in a pond. The effect is an electromagnetic (EM) wave which travels out from the initial location those results in electrons to wiggle in remote locations. An RF receiver can detect the remote electron wiggling. The RF communication system then further utilizes this phenomenon by wiggling electrons in a specific pattern so as to represent information. The receiver can make the same information available at a remote location by establishing a communication with no wires. In most of the wireless systems a designer has two overriding constraints: it must operate over a certain distance (range) and transfer a certain amount of information within a time frame (data rate)

L293D is the most commonly used driver for bidirectional motor driving applications. L293D is a 16 pin motor driver IC which is used to drive the motors. L293D is a dual H-bridge motor driver. It can be used to drive direct current on either direction. L293D can control two DC motors simultaneously in either direction. It is used as a current amplifier since it takes low current control signal as the input and provides high current signal as output. L293D can be used to drive small as well as big motors as well. L293D motor driver is available for providing user with ease and user friendly interfacing for embedded applications. It is easily compatible with any of the systems. It supports external power supply pins for motors.

## III. RF COMMUNICATION

RF frequency ranges from around 3 kHz to 300GHz .this corresponds to the frequency of radio waves and the alternating current which carry radio signal. It refers to the ac having such characteristics that if the current is input to an antenna an electromagnetic field is generated suitable for wireless broadcast and communication. In order to receiveradio signals an antenna must be used. This antenna will pick up thousands of radio signal at a time and for the same we need to use a radio tuner to tune into a particular frequency. This is done by using a resonator. Any RF field has a wavelength which is inversely proportional to the frequency. In the atmosphere, in the outer spaces, or anywhere in our ambience if frequency F is in MHz and the wavelength in meters, then  $S=300/f$ . The frequency of RFsignal is inversely proportional to the wavelength of the EM field to which it corresponds. At 9 KHz, the free-space wavelength is approx. 33 kilometers or 21 miles (mi). At the highest radio frequencies, the EM wavelengths measure around one millimeter (1mm). As the frequency is increasedbeyond the RF spectrum, EM energy takes the form of infrared (IR), visible, ultraviolet, X rays, and gamma rays.

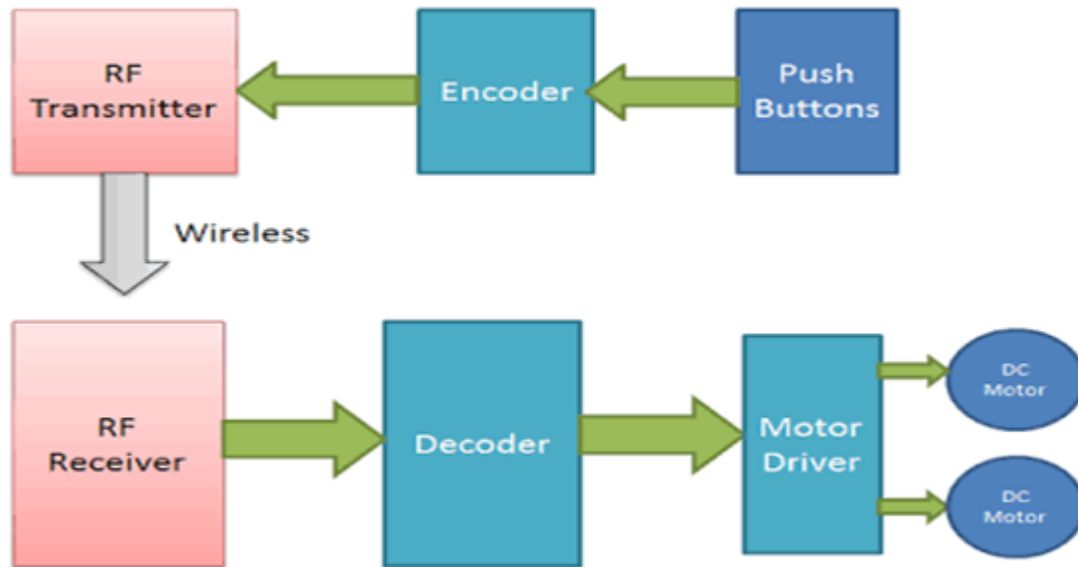

This is a 4 bit wireless module. Use it to transmit and receive 4 bits of data through a wireless RF Link. It uses our 433 MHz RF Modules and the HT12E/D IC. The transmitter and the receiver come with an 8 bit address selector switch which can be used to assign unique addresses to each wireless link. Receivers receive data only from transmitters which have a matching 8 bit address. The module can operate within a range of 100m when the transmitter is in line of sight and around 50m when indoors. This module takes care of all the encoding and decoding required to transmit data and requires no additional computation by the micro controller. Users can directly hook up the module to a micro controller and start transmitting data wirelessly. The transmitter and the receiver can be directly connected to a microcontroller or an external circuit through the header pins.

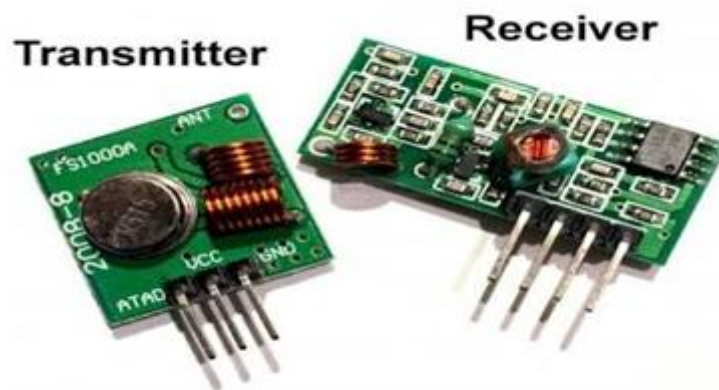

## RF TRANSMITTER:

- Pin 1 — Ground [GND]
- Pin 2 — Serial data input pin [DATA]
- Pin 3 — Power supply; 5v [Vcc]
- Pin 4 — Antenna Output pin [ANT]

## RF RECEIVER:

In this section a brief introduction about RF 433 MHz Receiver and HT12D (Decoder) is given individually following with the interface of the decoder with the receiver. This is a Hybrid 433MHz RF receiver module and is ideal for short-range wireless control applications where quality is a primary concern. The receiver module requires no external RF components except for the antenna. The super-regenerative design exhibits exceptional sensitivity at a very low cost.

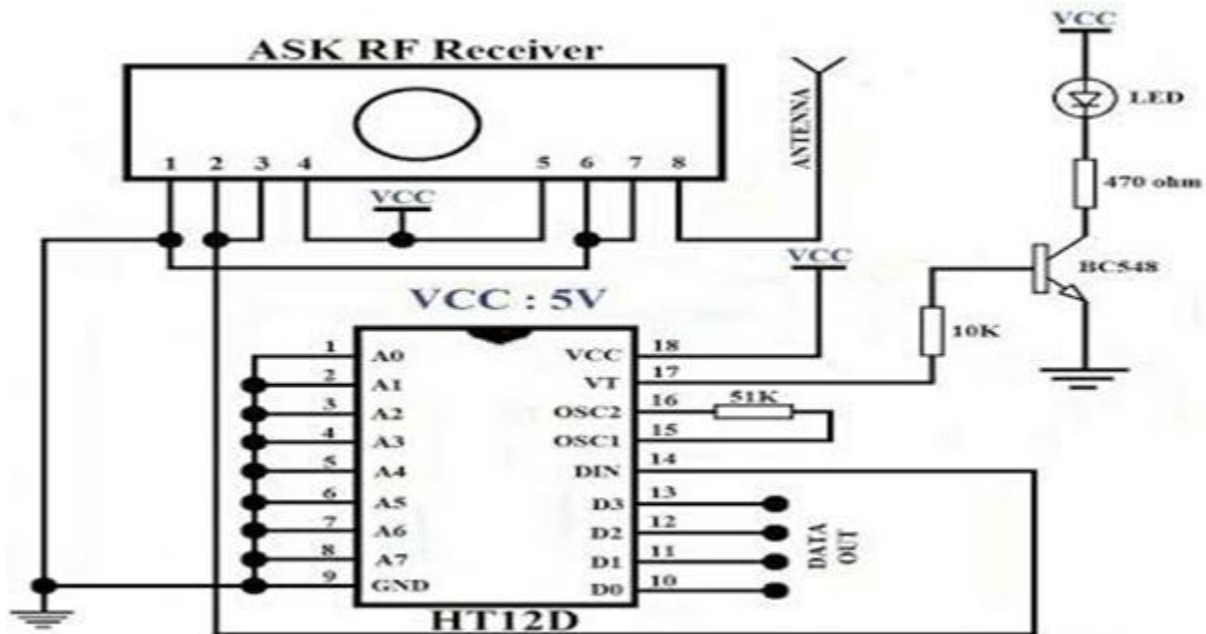

- Pin 1 — Ground [GND]
- Pin 2 — Serial data output pin [DATA]
- Pin 3 — Linear output pin (Not connected) [NC]
- Pin 4 — Power supply; 5v [Vcc]
- Pin 5 — Power supply; 5v [Vcc]
- Pin 6 — Ground [GND]

Pin 7 — Ground [GND]

Pin 8 — Antenna Input pin [ANT]

## Microcontroller Circuit (AT89S52)

It is the heart of the system as it controls all the activities of transmitting and receiving. AT89S52 IC is used. The AT89S52 Microcontroller is an 8-bit microcontroller of 8051 series with 8K Bytes of In-System Programming Flash Memory. Atmel's high-density nonvolatile memory technology is used for manufacturing of the device and is compatible with the industry standard 80C51 instruction sets. The on-chip Flash memory allows the program memory to be reprogrammed in-system or a conventional nonvolatile memory programmer is used. Atmel AT89S52 is a powerful microcontroller by combining a versatile 8-bit CPU with in-system programmable Flash on a monolithic chip, it provides a cost-effective and highly-flexible solution to many embedded control applications. The Idle Mode is used to stop the CPU while allowing the RAM, serial ports, timer/counters, and interrupt system to continue functioning. The Power-down mode is used to save the RAM contents but freezes the oscillator, and disables all other chip functions until the next interrupt or hardware reset occurs.

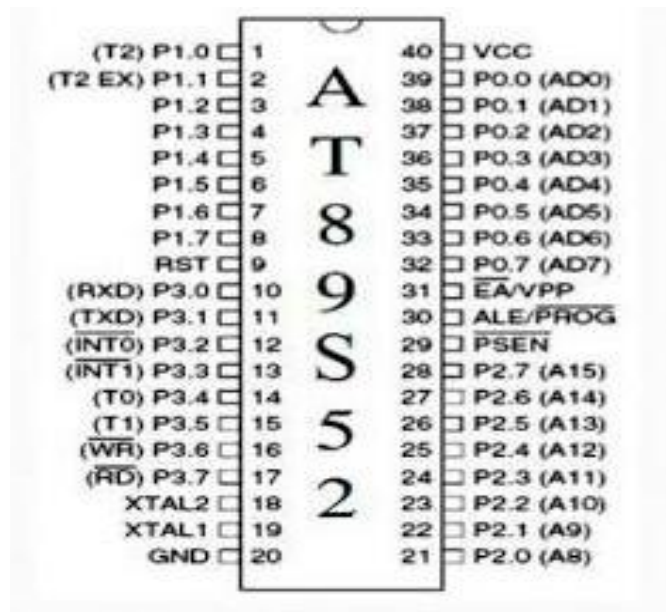

## Power Supply Circuit

Power supply is the main building block of any electronic system used to provide required power for their operation and For the microcontroller, keyboard, RTC, LCD, GSM, +5V are required and for driving a buzzer +12V is required. The power supply gives regulated output of +5V and non-regulated output of



+12. The three terminals IC780 provides +5V. The rectification of secondary voltage from the main transformer is done by electronic rectifier & filtration by capacitor. The unregulated DC voltage is supplied to the input pin of voltage regulator IC.

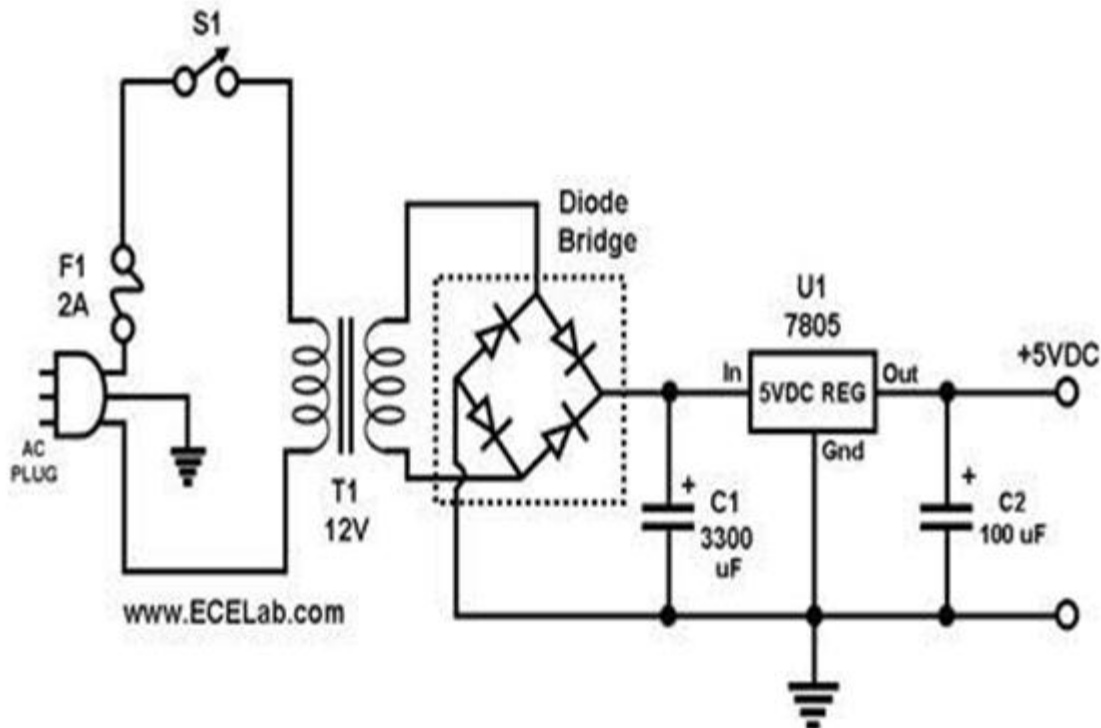

## Wireless Camera

We are using a wireless CCD camera, which are commonly available in the market. This camera works on 12 volts DC supply. The camera has a receiver, which is placed in the remote station. Its output are in the form of audio and video signals. These signals are directly sent to a television or a computer through a tuner card. This CCD camera is placed on the robot. The camera captures the audio and video signals and sends those signals to the remote station and with the help of the camera receiver which is connected to the television or a computer through we will be able to see the captured signals. This is a mini wireless monitoring video camera and wireless receiver set for home and small business surveillance, security and is used by us for demonstration purpose. We need to install the wireless camera in the room where we want to monitor and set the wireless receiver in the next room (up to 15 meters away) and hook it up to aTV or DVR to watch the action or record the footage for the security purpose. Here we are placing this wireless camera in the combat robot which would be present in the war field.



## IV. SOFTWARE IMPLEMENTATION

Audacity

1. It is free software available for the removal of noise.
2. It is a free open digital audio editor and recording computer software application, available for Mac OS X, Windows, Linux and other operating systems.
3. We can remove the unwanted noise from the audio/video which is coming at the receiver end [5].

## V. RESULT

With the help of this we aimed at obtaining the accuracy. It has been tested to best of our ability. We were able to view the things accurately that were happening. In our view. Our design has not caused any sort of disturbances. This robot will move based on the motor direction depending upon the input we give through command via remote section unit. With the help of camera we are able to view the things that are happening in the war field where the robot is hidden. The importing and exporting features of 'AUDACITY' in this project have helped to remove the unwanted audio signals. By using this software post process all type audio including broadcast by adding effects such as normalizing, trimming fading in and fading out.

## VI. CONCLUSION

The main motive of the war spying robot was to make it user friendly. The spy robot can easily move, capture images and wirelessly transmit them, thus giving the soldiers an intimation about the dangers and situations in the war field. The robot will move depending on the motor direction based upon the input we give through transmitter (remote) section. RF signals are used as control signals. By using these signals encoding is done & signal is sent through the transmitter. At the receiver end, these decoded signal are given as input to drive the motor. The robot is used for short distance surveillance thus ensuring the security of the region. This helps the forces to view the things



accurately that are currently happening in the surrounding area and to plan ahead accordingly. Thus we should be able to manipulate its path when necessary, to create the robot safely. To all that, a control unit is needed, where control units RF signal is used. By using these signals encoding is done & signal is sent through the transmitter. At the receiver end these decoded signal are given as input to drive the motor. Not for long range applications it can be used as a spy robot within short distances.

## VII. FUTURE ENHANCEMENT

We can connect this system directly to internet by using zig-bee with Wi-Fi. By using internet we can control the system via remote location. We do not require any simulation tool by using GUI software. Halogen light can be used for the vision of the robot. We can also control the device by giving it voice command thereby making it a voice recognition system.

## REFERENCES

- [1] HT12D datasheet [http://www.eleinmec.com/datasheets/ds\\_holtek\\_ht12d.pdf](http://www.eleinmec.com/datasheets/ds_holtek_ht12d.pdf)
- [2] <http://www.electronicshub.org/remote-operated-spy-robot-circuit/>
- [3] <http://www.scribd.com/doc/222143724/Major-Project-Report-on-War-Field-Spy-Robot#scribd>
- [4] Robert L Boylestad and Louis Nashelsky, "Electronic Device And Circuit Theory" ,8th edition 2006.
- [5] Mr Lokesh Mehta, Mr. Pawan Sharma "Spy Night Vision Robot with Moving Wireless Video Camera". International journal of research in engineering technology and management (IJRET), 2014.
- [6] The 8051 microcontroller and embedded system using assembly and C, 2nd edition (ISBN: 9780131194021) by Mazidi Muhammad Ali (2008).
- [7] Dhiraj Singh Patel "Mobile Operated Spy Robot" International journal of emerging technology and advanced engineering (IJETA), 2013.
- [8] IEEE xplore <http://ieeexplore.ieee.org/search /searchresult.jsp?newsearch=true&queryText=spyrobot&x=0&y=0>.